



Shipping & Mailing

Postage Meters

Connect+® Customer Communication Series

# Turn every envelope into an opportunity.





*Colour envelope messages can deliver 34% faster response rates and a 32% increase in overall revenues.<sup>1</sup>*

**Make sure it gets opened.**

The performance of your mail depends on the envelope. With one look, your customers decide to open it now, open it later or just throw it away.

Capitalise on that look. Add eye-catching colour, graphics and messaging to your envelopes to connect with your customers. Then watch your open rates go up, response rates accelerate and revenues rise.

**Make a profitable impact.**

Choose your colours. Pick your messages. Apply time-sensitive teasers and messaging as you apply your postage. It's easy to transform your bills, invoices and statements into promotional opportunities.

With full-colour in-line envelope printing, you'll produce print-shop quality promotional messages, graphics, postal indicia, and return addresses all in one pass.

**Make your envelopes work harder for you.**

Print designs and messages in the colour of your choice on your envelopes.

- Discount vouchers
- Special offers
- Promotional teasers
- Time-sensitive messages
- Eye-catching graphics and ads

**One-touch simplicity.**

With Connect+<sup>®</sup>, you'll complete tasks more quickly every time. Data entry is easy with an intuitive touch screen and onscreen keyboard. On-screen help provides instant support.

With the Connect+ Series, you can order ink, track parcels, check postcodes. All right from the home screen. It couldn't be easier.

1. CapVentures.

2. Lefflein Associates, International Study, 2010.

# Get your postage precisely right.

## Engage customers fast.

Connecting better with your customers won't slow you down. With throughput speeds of up to 300 letters per minute, you'll print and meter fast. The power stacker handles up to 600 mailpieces in a single run, or 1,200 with the optional self-expanding backstop.

## Get your postage precisely right.

With Connect+®, you'll neither over nor underpay. Weigh-on-the-Way™ in-line weighing and Dimensions-on-the-Way™ in-line rating automatically calculate precise postage as your items are processed.

Add an optional weighing platform to handle parcels from 5kg to 35kg, and you can add to your efficiency. With differential weighing, you put several items on the scale at once, and the machine will automatically apply the correct postage as you remove each one.

## Manage your costs. Maximise your discounts.

Automatically capture costs for chargebacks. Use password protection and real-time account validation to ensure security and accountability. Add surcharges as necessary. Apply postage discounts to maximise savings. With your Connect+ system, you'll have access to the full range of business-mail discounts, from metering to presort and more.

---

*Envelopes with colour promotional messages are up to 2½ times more likely to be opened.<sup>2</sup>*

## Easy-to-use apps-based operating system

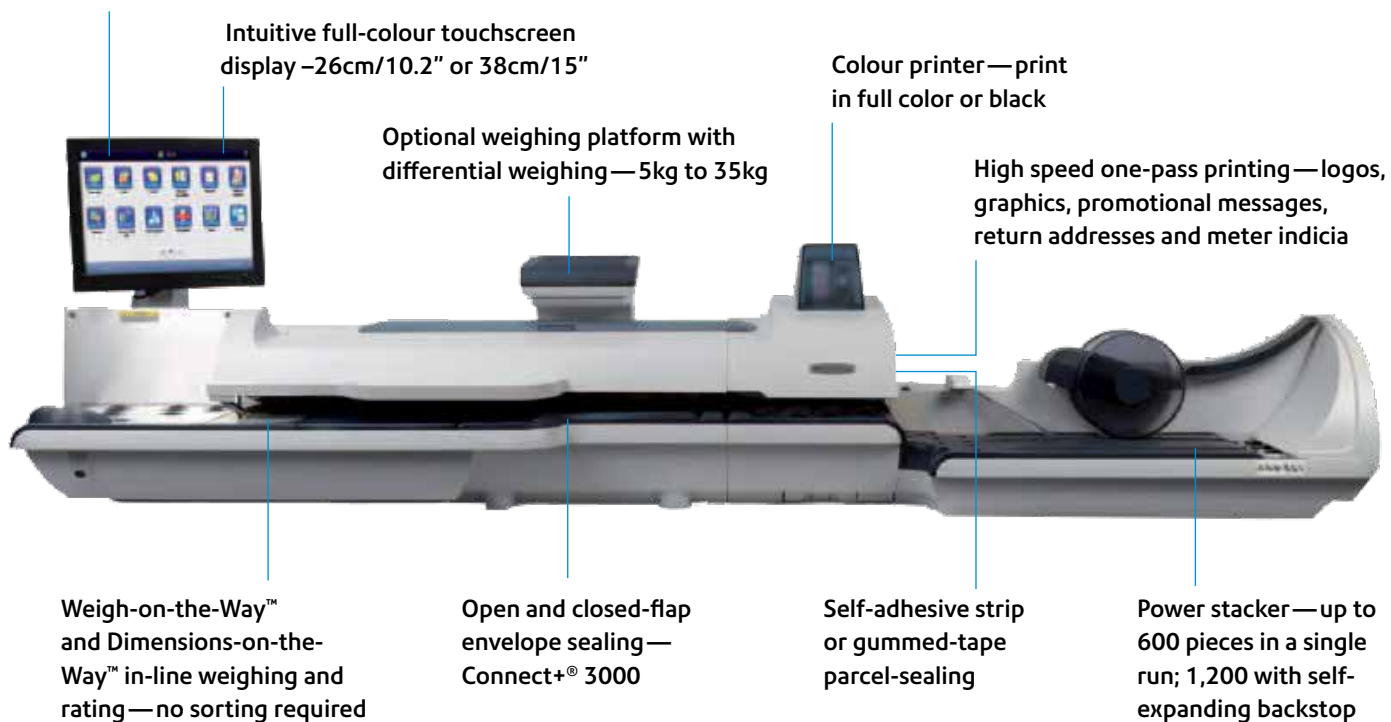

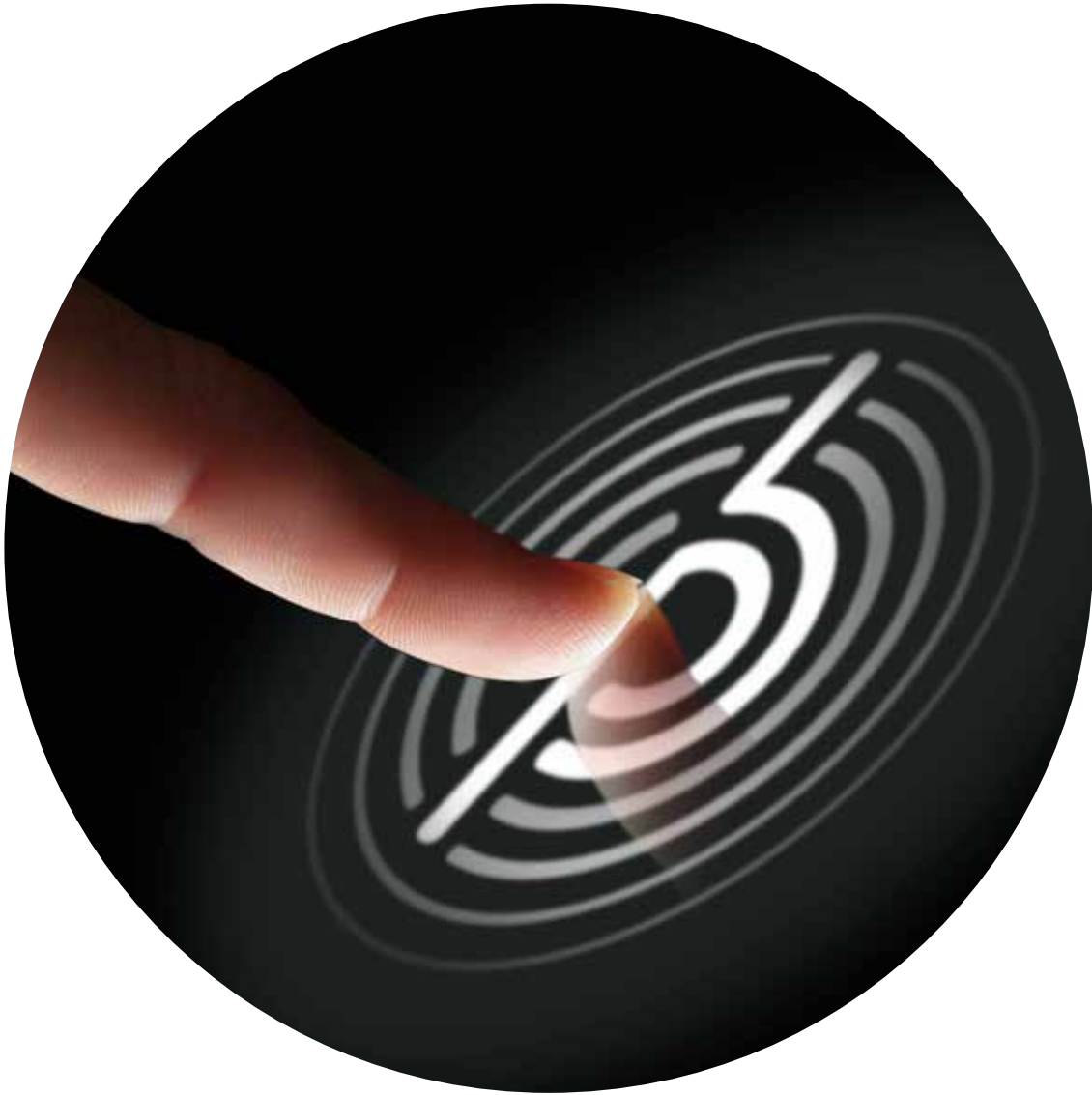

**Choose a system you can rely on.**

Web enabled. ENERGY STAR® compliant. Satisfaction guaranteed. You'll rest easy knowing your Connect+® Customer Communication Series solution is designed to highest standards and supported by a nationwide network of qualified professional services personnel.

Select the model that's best for your business.

<b>Features</b>	<b>Connect+® 1000</b>	<b>Connect+® 2000</b>	<b>Connect+® 3000</b>
Weighing options	5, 7, 12, & 35kg	5, 7, 12, & 35kg	5, 7, 12 & 35kg
Differential weighing	Standard	Standard	Standard
Accounts	From 100 standard, up to 500 optional	From 100 standard, up to 500 optional	From 100 standard, up to 500
Stacking options	Drop stacker or power stacker	Drop stacker or power stacker	Drop stacker or power stacker
Barcode scanner	Optional	Optional	Optional
External USB report printer	Optional	Optional	Optional
External USB report printer	Optional	Optional	Optional
Print colour	Postal fluorescent red, black and white, process colour	Postal fluorescent red, black and white, process colour	Postal fluorescent red, black and white, process colour
W-o-W™ Weigh-on-the-Way™	Not available	Standard	Standard
W-o-W™ weight limit	Not available	500g	500g
D-o-W™ Dimensions-on-the-Way™	Not available	Standard	Standard

<b>Specifications</b>	<b>Connect+ 1000</b>	<b>Connect+ 2000</b>	<b>Connect+ 3000</b>
System dimensions	With drop stacker Length 1,257mm x width 635mm Power stacker adds 483mm to length Colour adds 185mm to length	With drop stacker Length 1,638mm x width 635mm Power stacker adds 483mm to length Colour adds 185mm to length	With drop stacker Length 1,867mm x width 648mm Power stacker adds 483mm to length Colour adds 185mm to length
Weight	27.7kg	50kg	63.6kg
Print quality	1200 dpi	1200 dpi	1200 dpi
Processing speed (letters per minute)	Up to 180	Up to 90/160 (W-o-W™/Non W-o-W™) 110/180 (W-o-W™/Non W-o-W™)	160/260 (W-o-W™/Non W-o-W™) 200/300 (W-o-W™/Non W-o-W™)
Colour touch screen display/ user interface	26cm/10.2" standard 38cm/15" optional XGA	26cm/10.2" standard 38cm/15" optional XGA	26cm/10.2" standard 38cm/15" optional XGA
Media size	Minimum size: 89 x 127mm Maximum size: 254 x 356mm	Minimum size: 89 x 127mm Maximum size: 254 x 356mm	Minimum size: 89 x 127mm Maximum size: 254 x 356mm
Envelope flap depth	25 to 98mm (for sealing)	25 to 98mm (for sealing)	25 to 98mm (for sealing)
Envelope max thickness (sealing)	Up to 16mm	Up to 16mm	Up to 19mm



Say goodbye to pre-printed envelopes. When you print just what you need there's no inventory to manage, and no waste of paper, ink or space.



**Australia**

Level 1, 68 Waterloo Road  
Macquarie Park NSW 2113  
13 23 63  
[pitneybowes.com/au](http://pitneybowes.com/au)

**New Zealand**

Building B, Unit 2 & 3  
72 Apollo Drive  
Rosedale  
Auckland 0632  
0800 748 639  
[pitneybowes.com/nz](http://pitneybowes.com/nz)

For more information, call or visit us online.