

Pitney Bowes Smart Access Management® (SAM)

**Delivering assurance.  
Inspiring confidence.**

**SAM Desktop**

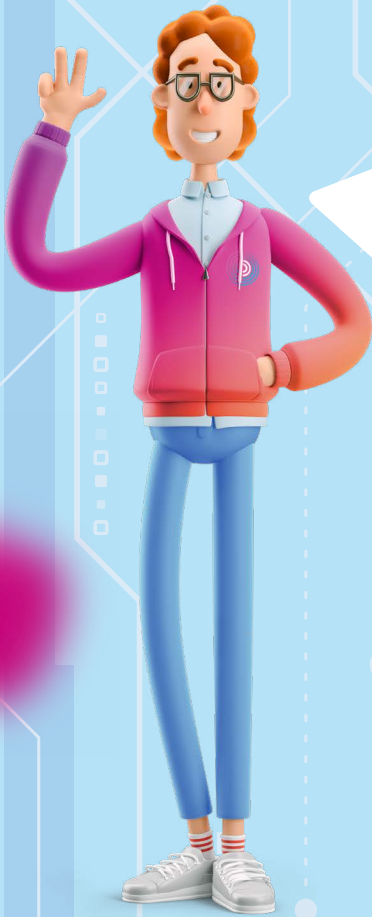

**Hi – I'm SAM**, let me be your Digital Concierge. I know how tricky it can be for businesses to manage visitor access in today's hybrid world of work. I'd like to help you protect your organisation. Let my intelligence provide you with all the information and insight you need to manage and control your physical and digital spaces.

Speak to Pitney Bowes today to find out more about how I can help:

- Create a **welcoming, actively managed** environment for authorised people
- Deliver **intelligent technology for constantly changing requirements** and back-end prerequisites
- **Protect your people, premises and reputation** through effortless enforcement of security and compliance while providing a warm welcome for your visitors.

## SAM features:

Self-setup custom workflows for each visitor type

Facial recognition for an even simpler way to sign in

Unlimited sign-in and sign-out provides maximum flexibility

Policies, NDAs and declarations sent by email

Zero touch access via QR code for staff and frequent visitors

Large screen with customisable graphics and appearance for brand consistency

Email and SMS notifications when a contractor or visitor arrives



# Pitney Bowes Smart Access Management® - SAM Desktop

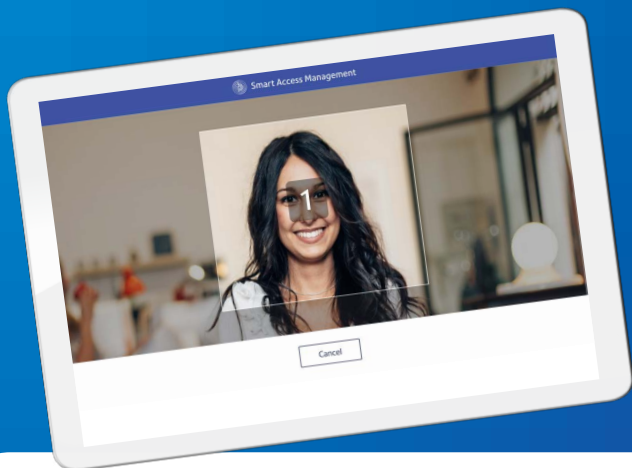

Specifications	SAM Desktop
Dimensions	210 x 268 x 273 mm (HxWxD)
Camera	Integrated camera
Touchscreen	12.4" display
Printer	Self cutting badge printer
Connectivity	Wi-Fi & Bluetooth for wireless printing
Operating System	Android
Screen	Pivoting screen

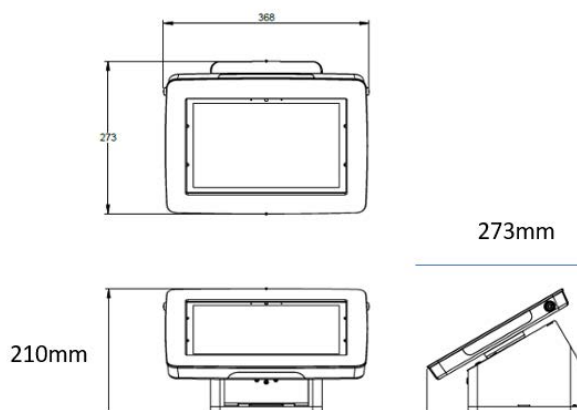

## Select the subscription level that fits your organisation

### SAM

- ✓ Unlimited visitor & staff sign-in/out
- ✓ Contactless sign-in via QR code
- ✓ Frequent visitor sign-in
- ✓ Visitor health & safety info
- ✓ Blacklist visitors
- ✓ Visitor labels printing
- ✓ Visitor auto sign-out
- ✓ Email & SMS\* notifications
- ✓ User management
- ✓ Active directory integration
- ✓ Online dashboard & reports
- ✓ Emergency printouts
- ✓ Screen & settings customisation

\*SMS notification will incur extra charges per SMS.

### SAM Pro

- ✓ As per **SAM, plus:**
- ✓ API availability/integrations
- ✓ Facial recognition
- ✓ Unlimited workflows
- ✓ Site management
- ✓ Email visitor NDA/declarations
- ✓ Set visitor limits



**United Kingdom**

Langlands House  
130 Sandringham Avenue  
Harlow  
CM19 5QA

For more information visit us online:

[pitneybowes.com/uk/smart-access-management](https://pitneybowes.com/uk/smart-access-management)