

DM100i / DM125 with Standard Scale Return Instructions

IMPORTANT NOTICE: Postage Meter Return is Mandatory. Please follow the prepaid shipping instructions to return postage meter. Following these steps will avoid the \$1000 fee for failure to return your meter.

1. Withdraw the remaining funds from your meter.

Transfer the remaining postage in your meter into your Postage by Phone account to insure that your funds will be available to fill your replacement meter immediately.

If this is not possible, you can use up all the remaining postage before returning the meter.

If you can not withdraw your remaining funds, then proceed to Step 2. Pitney Bowes will transfer your funds into your Postage by Phone account within 6-10 days of receiving your meter.

A. To have a record of the amount of postage in the meter, print the Funds Report by pressing the **Funds** key, then pressing the **Page Down** twice, and then by selecting **Print Funds** Report. Insert an envelope to obtain a record of the transaction.

B. Keep your meter connected as you normally would for a postage refill.

C. Press **Options** on your meter keypad.



D. Press **Page Down** twice. Select **Advanced Features**.

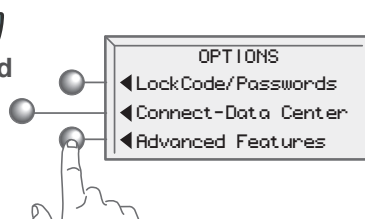

E. Select **Meter Withdrawal**. You may need to press **Page Down** to see this option.



F. Select **Transfer all funds from Meter to PBP account**.



The postage meter will connect with the Data Center, and the meter screens will let you know the status of the process.

G. When the **FUNDS TRANSFERRED** screen displays, select **OK** and eventually the meter will display **OUT OF SERVICE** No postage can be dispensed. If you see any other message, press Clear and call Pitney Bowes at 1-800-522-0020.

Once your funds have been credited back to your Postage by Phone account we'll mail you a final statement showing balances/credits, along with further instructions for your refund.

2. Disassemble the old meter.

Keep the meter plugged in during this step.

A. Open the top cover of your meter and select **Replace Ink Tank**. When the printing mechanism moves forward, remove the ink cartridge.

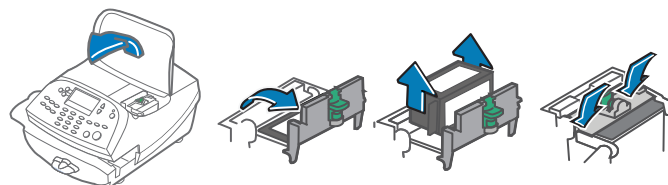
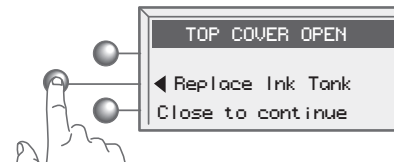

Ink may stain skin or permanently damage clothing. Gloves are included for your convenience.

Close the ink cartridge guard and meter cover.

B. Wait five seconds and then disconnect all the cords from the back of the meter.

C. Re-open the meter's top cover. Separately crumple the two folded cloths provided in the kit and insert them, on top of each other, in front of the printer mechanism as shown.

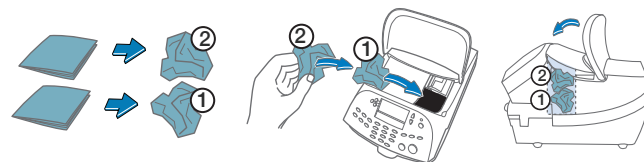

D. If your unit has the moistener, remove that by pushing down on the blue lever and pulling it straight out to the left.

E. If you are using the stacker tray, slide that away from the meter.

F. If your meter has a scale, remove it now by lifting straight up and off as shown.

G. If your system has the ink waste drawer, pull the ink drawer out from the side of the meter. Remove the ink tray and dispose in bag provided. Place the empty drawer back into the meter.

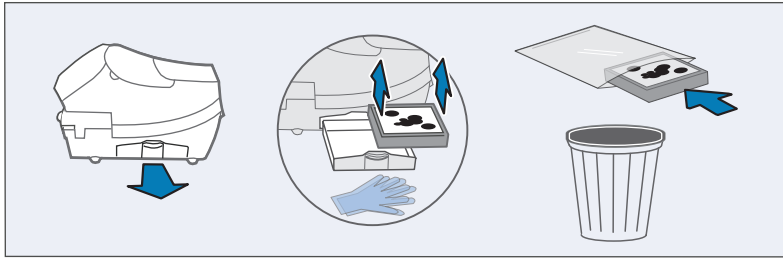
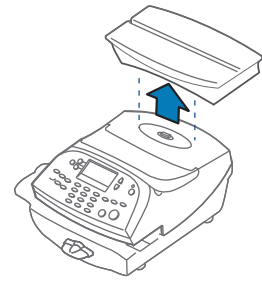

3. Pack the meter for shipment back to Pitney Bowes.

Everything you need to return your system is included in the white box that your replacement meter arrived in and the additional brown box.

A. Place the meter inside the plastic bag provided.

B. Place the meter in the **white** box as shown in the illustration. If you are returning a scale, pack it as shown.

C. The below list of items can be returned along with any cords in the **brown** box. Separate items with the provided bubble wrap.

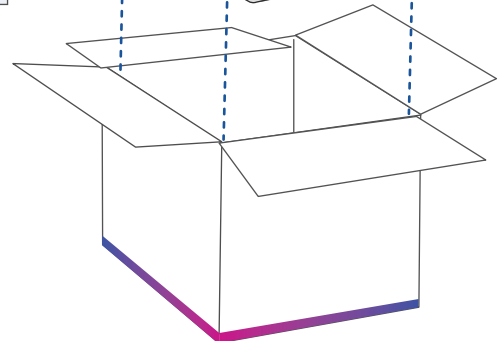
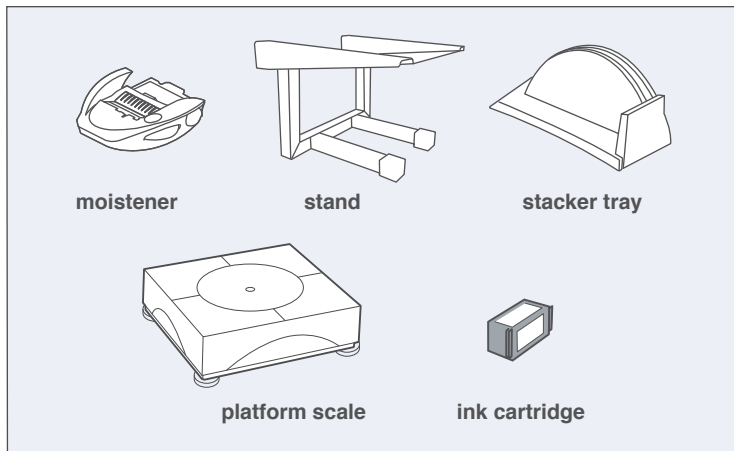
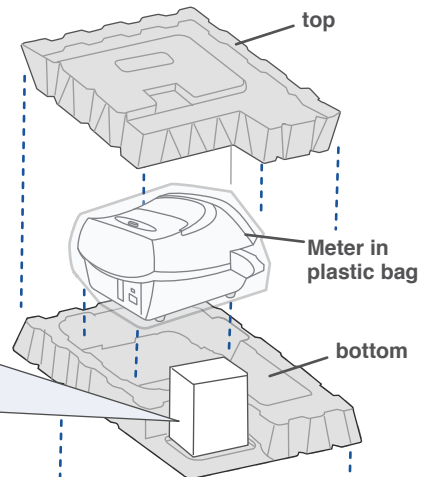
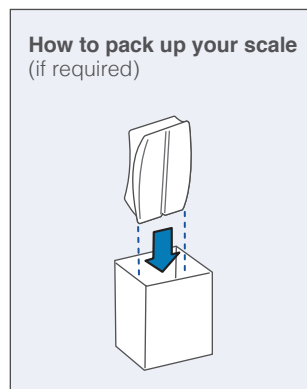

D. Seal the tops of the cartons with tape provided.

E. Apply a prepaid UPS shipping label to each box over old shipping labels and return via your local UPS agent or drop off location.

F. Keep the customer portions of the prepaid shipping labels so you can track your shipment.

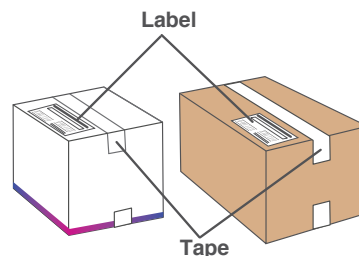
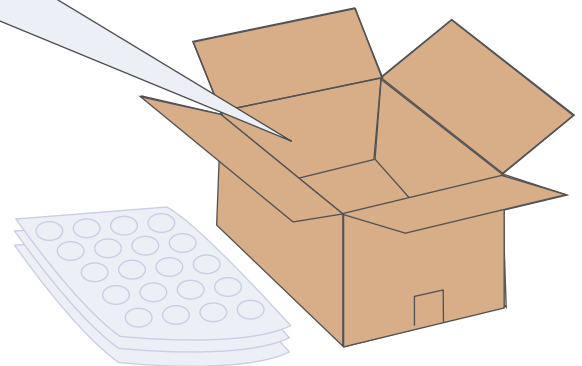

If additional packaging is needed or if you have questions, contact client support at www.pitneybowes.com/us/returns