

DM300c / DM400c / DM450c / DM475 Ink Tray Replacement Instructions

1. Replace Ink Tray

- A. Remove ink tray from envelope and set both tray and envelope aside.

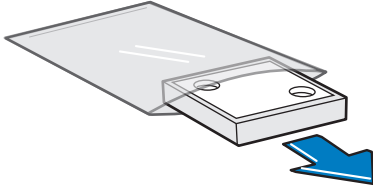

- B. Pull ink drawer out from side of meter. Remove ink tray.

WARNING: Ink may stain skin or permanently damage clothing. Gloves are included in the kit for your convenience.

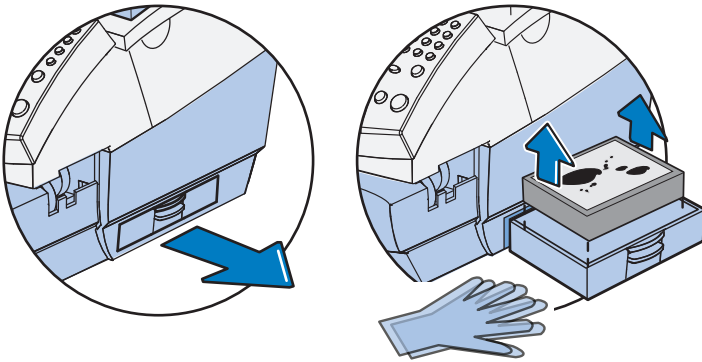

- C. Dispose of used ink tray in envelope that new ink tray came in.

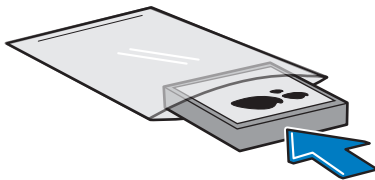

- D. Insert new ink tray into ink drawer and close drawer.

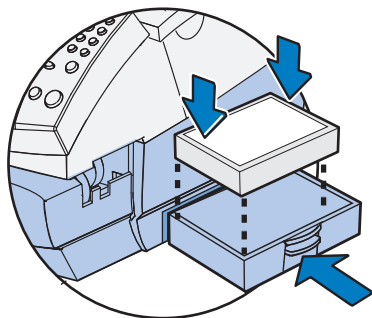

2. Enable Meter Printing

Note: Do not unplug power cord until instructed.

If you see an ink tray message on your home screen, follow these steps to remove it and enable postage printing.

- A. From the home screen, select **Menu**, then **Maintenance**.

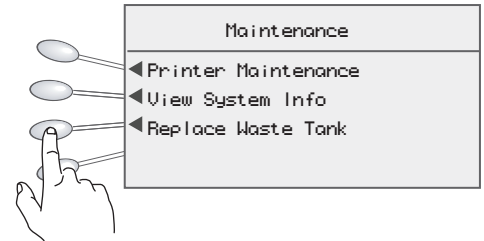

- B. Select **Replace Waste Tank**.

- C. **Important:** Please do not use your meter without the waste Ink tray installed. Select **OK, I understand** to proceed.

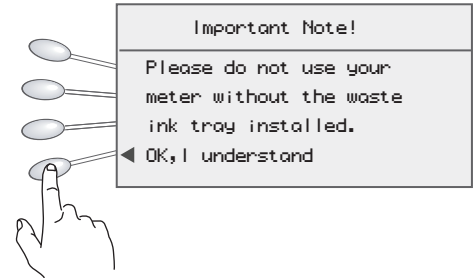

- D. Select Yes, tray is replaced.

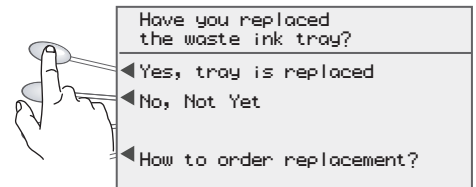

The ink tray message on your home screen will now disappear and postage printing will be enabled.

If you have any questions, call Pitney Bowes at **1-800-522-0020** or go to www.pbdirectreturn.com

DM125 / DM225 Ink Tray Replacement Instructions

1. Replace Ink Tray

- A. Remove the new ink tray from the plastic bag.

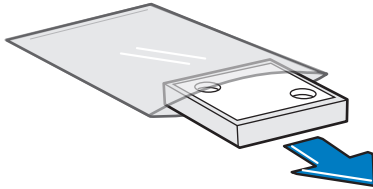

- B. Pull ink drawer out from side of meter. Remove ink tray.

WARNING: Ink may stain skin or permanently damage clothing. Gloves are included in the kit for your convenience.

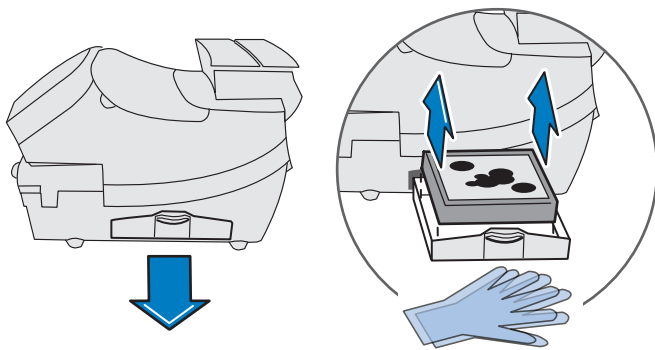

- C. Dispose of used ink tray in envelope that new ink tray came in.

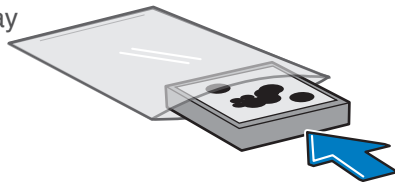

- D. Insert new ink tray into ink drawer and close drawer.

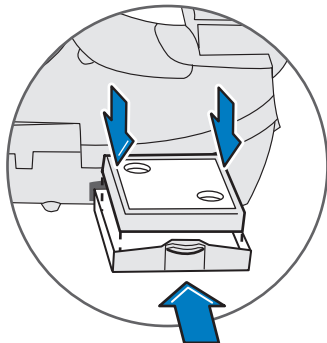

2. Resetting the Ink Tank Counter

- A. From the home screen, select the **Options** key, press the **Page Down** button twice. Select **Advanced Features**. Select the **Maintenance Mode** option, and then select **Printer Maintenance**.
- B. From the PM MAINTENANCE screen, press the **Page Down** button and then select the **Reset Waste Tank** option.

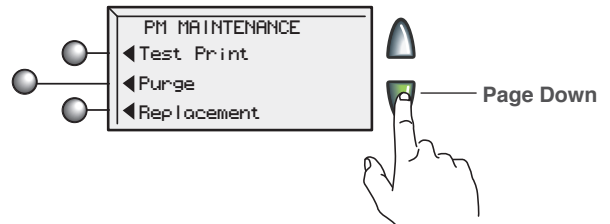

- C. Select **Yes**, to confirm resetting the waste ink tank counter to zero.

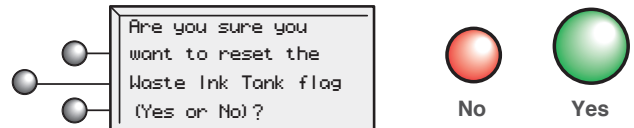

- D. Enter the 4-digit code that is printed in the upper right corner of this sheet. Select **Continue** to proceed.

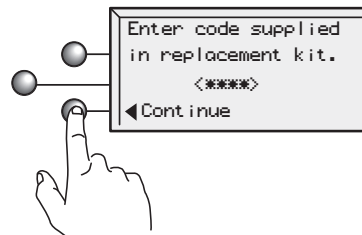

- E. Select **Press** to restart. Postage printing will be enabled.

