

Operator Guide

OfficeRight™ Inserting System DI200



Statement of FCC Compliance

This equipment has been tested and found to comply with the limits for a Class A digital device, pursuant to part 15 of the FCC rules. These limits are designed to provide reasonable protection against interference when the equipment is operated in a commercial environment. This equipment generates, uses, and can radiate radio frequency energy and, if not installed and used in accordance with the instruction manual, may cause interference to radio communications. Operation of this equipment in a residential area is likely to cause interference, in which case the user will be required to correct the interference at his own expense.

Canada

This class A digital apparatus complies with Canadian ICES-003.

Cet appareil numérique de la classe A est conforme à la norme NMB-003 du Canada.

CAUTION: Changes or modifications to this equipment not expressly approved by the party responsible for compliance (Pitney Bowes) could void the user's authority to operate the equipment.

SV40189-OG Revision C February 2005 ©2005 Pitney Bowes Inc.

All rights reserved. This book may not be reproduced in whole or in part in any fashion or stored in a retrieval system of any type or transmitted by any means, electronically or mechanically, without the express, written permission of Pitney Bowes.

We have made every reasonable effort to ensure the accuracy and usefulness of this manual; however, we cannot assume responsibility for errors or omissions or liability for the misuse or misapplication of our products.

Due to our continuing program of product improvement, equipment and material specifications as well as performance features are subject to change without notice.

OfficeRight is a trademark and E-Z Seal is a registered trademark of Pitney Bowes.

	Page
1. Introduction	
Important Safety Information.....	4
About Your Machine	5
Machine Configurations	5
Machine Controls, Indicators and Features	6
The Controls	8
2. Preparing and Loading	
Connecting Power and Turning On	10
Filling the Moistener.....	11
Loading the Sheet Feeders (Feeders A1 and A2)	12
Loading the Envelope Feeder (Feeder B)	13
Loading the Insert Feeder (Feeder C).....	14
3. Running Jobs	
Job Listing.....	15
Job 1: One Folded Sheet into an Envelope	17
Job 2: One Folded Sheet, No Envelope (Fold Only)	18
Job 3: One Folded Sheet + One Insert into an Envelope	19
Job 4: One Insert into an Envelope.....	21
Job 5: Two Folded Sheets into an Envelope	22
Job 6: Two Collated, Folded Sheets into an Envelope	23
Job 7: Two Folded Sheets, No Envelope (Fold Only).....	24
Job 8: Two Collated, Folded Sheets, No Envelope (Fold Only).....	25
Job 9: Two Folded Sheets and an Insert into an Envelope	26
Job 10: Two Collated, Folded Sheets and an Insert into an Envelope	28
The Manual Feeder M.....	30
4. Advanced Menu Options	
Reset Counter.....	31
Change Paper Size	32
Move the Address in the Window	32
Sheet Double Detect On/Off	33
Insert Double Detect On/Off.....	34
Safe Seal On/Off	34
5. Reference	
Error Messages.....	35
General Troubleshooting	39
Clearing Material Jams	40
Getting Help	41
Ordering Supplies	42
Material Specifications	43
Machine Specifications	44
Index	45

1. INTRODUCTION

Important Safety Information

- Please read all the instructions in this manual *before* you attempt to operate your OfficeRight™ DI200. Save all instructions.



WARNING! Always use the power cord supplied with your machine and plug it into a *properly grounded* wall outlet that's located near the machine and easily accessible. Failure to properly ground the machine can result in severe personal injury and/or fire.

- DO NOT use a wall outlet controlled by a wall switch or one that is shared with other equipment.
- Do not use an adapter plug on the line cord or wall outlet.
- Do not remove the ground pin from the line cord.
- Make sure the area in front of the wall outlet into which the machine is plugged is free from obstruction.
- DO NOT route the power cord over sharp edges or trap it between pieces of furniture. Make sure there is no strain on the power cord.
- To reduce the risk of fire or electrical shock, DO NOT attempt to remove covers or disassemble the inserter. The cabinet encloses hazardous parts. Refer servicing to qualified personnel.
- Keep fingers, long hair, jewelry and loose clothing away from moving parts at all times.
- Never reach into the machine while it is running. Avoid touching moving parts or materials while the machine is in use. Before clearing a jam, be sure all machine mechanisms come to a complete stop.
- Know your equipment, especially *how to stop it in the event of an emergency*.
- When removing jammed material, avoid using too much force to protect against minor personal injury and damage to the equipment.
- Use the equipment only for its intended purpose.
- Always follow the specific occupational safety and health standards prescribed for your workplace.



CAUTION! If you relocate an OfficeRight™ DI200 that has the optional Second Sheet Feeder A2 installed, remove it from the Second Sheet Feeder first—that is, as you lift it clear, make sure it fully disengages from the Second Sheet Feeder. Obtain help if necessary.

About Your Machine

Your new OfficeRight™ DI200 is a compact folding and inserting machine designed to speed the process of mail creation.

It has a minimal number of user adjustments and an intuitive, easy-to-use control panel. This greatly simplifies machine operation and will enhance the productivity of your mailing operation.

Machine Configurations

There are two configurations of the OfficeRight™ DI200 available. The basic model is supplied with an insert feeder and one sheet feeder. The second configuration is supplied with an insert feeder and two sheet feeders.

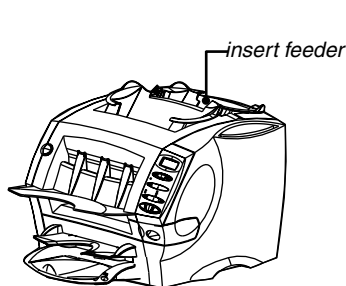

Configuration 1
Basic machine with insert feeder and one sheet feeder

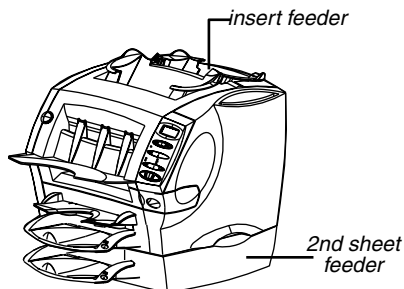

Configuration 2
Machine with insert feeder and a 2nd sheet feeder added

Introduction

Machine Controls, Indicators and Features

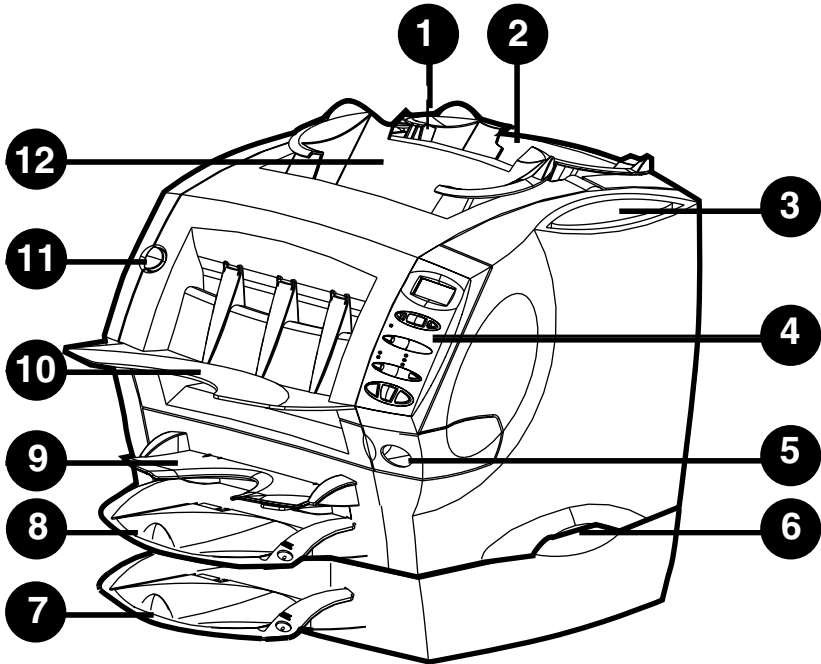

- 1. Insert Cover E Release Button (Blue Button Marked E)**
Press this button to release the insert cover if a jam occurs in this area of the machine. The display prompts you if you need to open this cover to remove jammed material.
- 2. Insert Feeder (Not on All Models)**
Use this feeder to add additional inserts to your envelope. Material fed from this feeder *cannot* be folded by the inserter. However, this feeder is especially suited to feeding pre-folded or thicker inserts.
- 3. Operating Guide Slot**
Store this Operating Guide in the slot provided so that it doesn't get lost and is readily available when you need it.
- 4. Control Panel**
This is where you enter commands and where the machine informs you of its status. See pages 8 and 9 for a full explanation of what each button does.

5. Moistener Tank

This tank contains E-Z Seal® solution or water to moisten and seal envelope flaps. It slides out to the right for refilling and has an oval level indicator window at the front so you can easily check fluid level.

6. Lifting Handles (One Each Side)

Always lift the OfficeRight™ DI200 using the side handles. DO NOT lift the machine by any of the feeders or the stacker.

7. Second Sheet Feeder A2 (Optional)

You can add this feeder to the machine to enable folding and inserting of a second sheet into the envelope. It functions in exactly the same way as the standard sheet feeder, A1.



IMPORTANT: When you use both sheet feeders A1 and A2 together, always load the address bearing sheet into sheet feeder A2. If you fail to do this, the address won't show in the envelope window. Always load sheets into feeder A2 *face down* and *bottom edge first*, that is, with the bottom edge of the sheet furthest into the machine.

8. Standard Sheet Feeder A1

This feeder enables folding and inserting of a sheet into the envelope. Always load sheets into this feeder *face down* and *bottom edge first*.

9. Manual Feeder M

Use this feeder to manually feed stapled sets of *up to three sheets each*. The machine waits for you to feed each set by hand into this feeder before it folds and inserts the set automatically. Always feed sheets into this feeder *face down* and *bottom edge first*, that is, with the bottom edge of the sheet furthest into the machine.

10. Stacker

The machine delivers finished pieces to this area.

11. Front Cover D Release Button (Blue Button Marked D)

Press this button to release the front cover if a jam occurs in this area of the machine. The display prompts you if you need to open this cover to remove jammed material.

12. Envelope Feeder B

This feeder feeds envelopes into the inserting area where they are filled with sheets or inserts from other feeders.

Introduction

The Controls

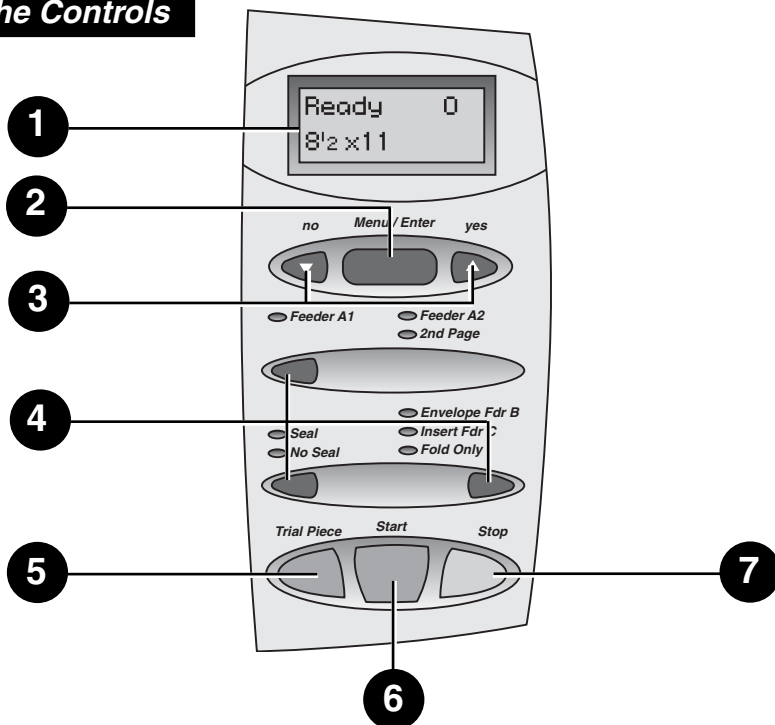

1. Display

Shows the current status of your OfficeRight™ DI200 and displays prompts or error messages which help you in operating the machine.

2. Menu/Enter

Press this button to enter the menu options. Options available are:

- Reset Counter
- Change Paper Size. Choose 11" (letter size) or 14" (legal size)
- Move Address in Window
- Turn Sheet Double Detection On/Off
- Turn Insert Double Detection On/Off
- Turn Safe Seal On/Off

3. yes▲ and no▲ buttons

Once you've entered the menu using Menu/Enter, press these buttons to answer **yes** or **no** to prompts. You also use them to change (increase or decrease) settings offered by menu options.

4. Selection Buttons and Indicator Lights

Press these buttons to step through the feeders and options that are available on your machine.

Depending on your model configuration, some indicator lights and associated feeders may be inoperable. If your model doesn't have a second sheet feeder, for example, the indicators associated with this feeder will not light. This is normal.

A *green indicator* shows that a feeder or function is selected for use.

A *red indicator* shows that you selected an invalid (impossible) combination of functions. Simply correct the error in selection and the indicator(s) will change back to green.

An *unlit indicator* means that the feeder or function is turned *OFF*.

5. Trial Piece

After you've set up a job using the control panel, you *must* run a trial piece. If you press Start before running a trial piece, the machine display will prompt you to run a trial piece first.

Press this button to run one fully collated piece as programmed via the control panel. The envelope will not seal regardless of whether the system has been told to seal or not. This allows you to inspect the processed job to make sure that everything is inserted correctly and that the address appears in the window.

The trial piece also allows the system to calibrate itself and set its double detect feature, if selected.



IMPORTANT: Running the trial piece is an *essential* function for the machine to perform. You *must* do it before a start every time you use a new batch of material. This allows the system to re-calibrate in case different batches of material vary slightly.

6. Start

Press to begin automatic operation.

7. Stop

Press to stop automatic operation at the end of the next cycle.

About the Sleep Mode

After 10 minutes of inactivity, the system enters a power-saving "sleep mode" and displays **Powersave On**. Pressing any button will wake the machine up. The machine remembers the last job setup.

Loading

2. PREPARING AND LOADING

This chapter explains how to connect and load the machine.

Once you understand the subjects covered in this chapter, you can quickly set up and use the machine for a variety of jobs as explained later in Chapter 3, *Running Jobs*.

IMPORTANT: Before running a job, make sure your material meets our published specifications (see *Specifications* on page 43). This helps assure reliable operation and greatest productivity.

Connecting Power and Turning On

WARNING! Read all the safety information on page 4 *before* connecting the machine.

Connect the power cord to the socket on the back of the machine.

Plug the power cord into a suitable power outlet. Make sure the power outlet is near the machine and is easily accessible.

Turn the power switch ON. After a few seconds, the display shows *Ready*.

When turned ON, the machine remembers the last job setup, but resets the item counter back to zero automatically.

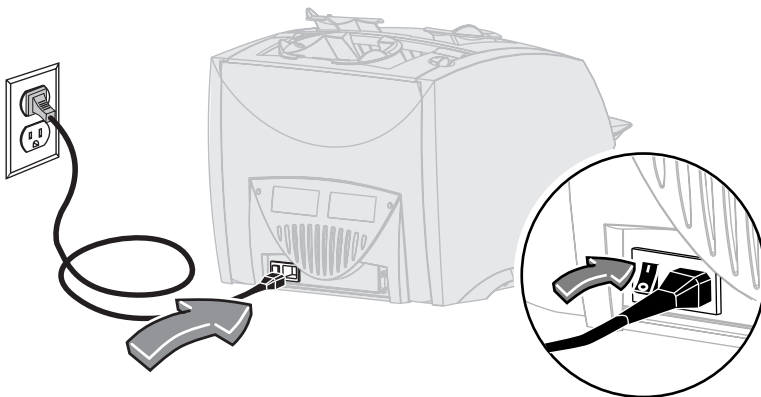

IMPORTANT: When the machine is first turned ON, the message “Check Moistener” appears on the display until any other button is pressed. *This is only a reminder.* As an additional reminder, this message appears every 1,000 cycles at the end of a batch or when the Stop button is pressed.

Filling the Moistener

Refill the moistener when the fluid gets low. Check fluid level through the oval viewing window (figure, below right).

Slide the moistener out to the right.

IMPORTANT: Never open the moistener while the machine is processing material.

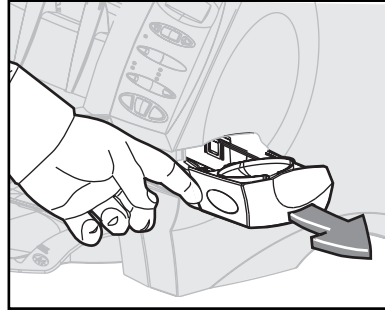

Carefully fill the moistener with E-Z Seal® solution or water up to the “Max” mark in the filler funnel.

We recommend E-Z Seal® to minimize algae growth and scale buildup.

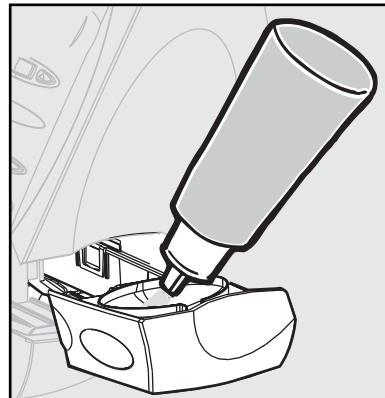

Slide the moistener back into the machine.

From the dry state, the moistener will take about five minutes to become fully wet and ready for use.

Loading

Loading the Sheet Feeders (Feeders A1 and A2)

Sheet Feeder A1 is common to all models and is located immediately below the Manual Feeder M. Sheet Feeder A2 is an option on all models. It allows the machine to insert a second folded sheet into an envelope.

Both feeders are used for sheets that require folding before inserting. Load both feeders in exactly the same way.

Always fan (aerate) sheets before you load them. This prevents them from sticking together.

Then tap the stack of sheets onto a firm surface to align the edges.

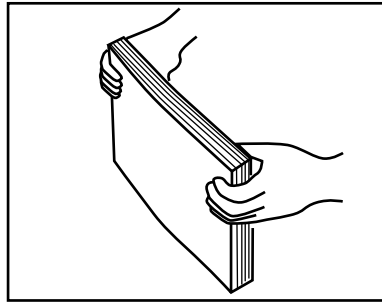

Place the sheets into Sheet Feeder A1 or A2 as required.



IMPORTANT:

Always load sheets into these feeders *face down* and *bottom edge first*. The bottom edge of the sheet is furthest into the machine.

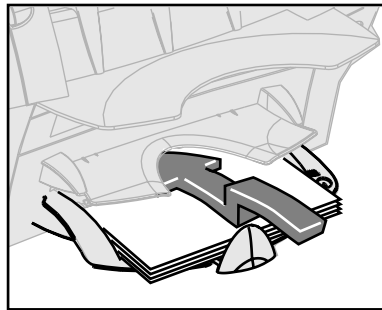

If you're using both Sheet Feeders A1 *and* A2 at the same time, you *must* load the document printed with the address into **Sheet Feeder A2**. If you load the address-bearing document into Sheet Feeder A1, *the address won't be visible in the envelope window*.

Slide the back stop in until it just touches the paper stack.

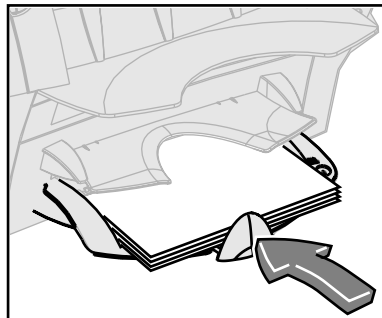

Loading the Envelope Feeder (Feeder B)

Always fan (aerate) envelopes before you load them. This prevents them from sticking together.

Then tap the stack of envelopes onto a firm surface to align the edges.

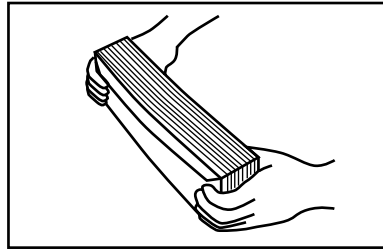

IMPORTANT:

Load envelopes right way up and facing you. This means that the envelope flap is on the back of the envelope and at the top. Any other orientation will prevent the machine from inserting properly.

Place the envelope stack into **Feeder B** with the back envelope flat against the feed belts. There's no need to "shingle" or stagger the envelope stack.

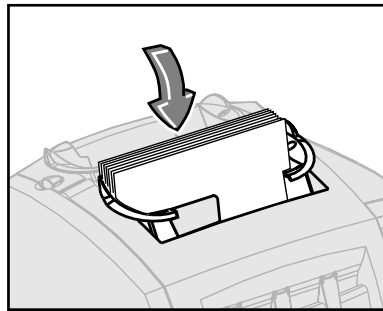

Slide the two side guides up to the envelope stack then *slightly* back them off. Use the blue handles at the rear of the guides when moving them.

The correct setting is achieved when the guides control the envelopes but in no way restrict their feed into the machine or cause them to feed at an angle (skew).

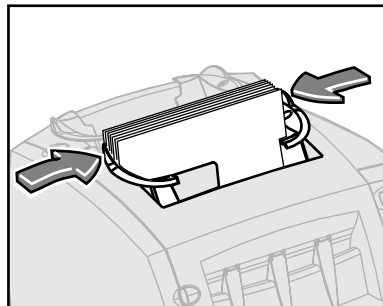

IMPORTANT: If the guides are too tight, envelopes may not feed reliably; if the guides are too loose, envelopes may skew as they feed into the machine.

Loading

Loading the Insert Feeder (Feeder C)

Insert Feeder C is only available on certain machine configurations. Use this feeder to add additional inserts to your envelope that *do not* require folding by the machine. Feeder C is especially suited to feeding pre-folded or thicker inserts such as business reply envelopes (BREs), response cards and similar materials.

Always fan (aerate) inserts before you load them. This prevents them from sticking together.

Then tap the stack of inserts onto a firm surface to align the edges.

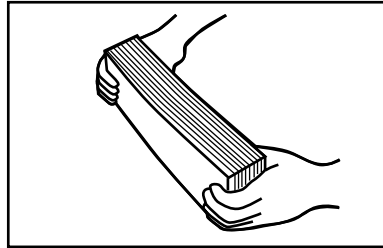

Place the insert stack into **Feeder C**.

IMPORTANT: The orientation of the insert stack depends on the nature of the material being run. For pre-folded inserts, it's normally best to load with the "closed" edge feeding first. You can usually load business reply envelopes right way up and facing you. However, if the flaps are pulled open when feeding, try loading the envelopes with the flaps down and facing you.

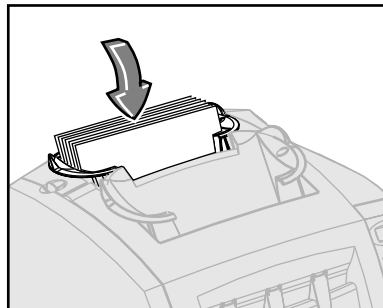

Slide the two side guides up to the insert stack then *slightly* back them off. Use the blue handles at the rear of the guides when moving them.

IMPORTANT: The setting is correct when the guides control the inserts but in no way restrict their feed into the machine or cause them to feed at an angle (skew). If the guides are too tight, inserts may not feed reliably; if they are too loose, inserts may skew as they feed into the machine.

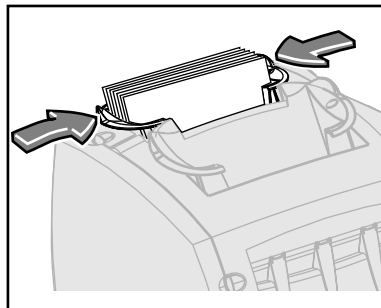

3. RUNNING JOBS

Chapter 1 explained the main features of the machine and how to use the control panel. Chapter 2 described how to turn the machine ON and load the feeders and moistener unit.

This chapter assumes you understand the content of the previous chapters. It includes illustrations that identify the various jobs you can run on your OfficeRight™ DI200, and then gives a table of quick steps to set up and run each job.

Once you're familiar with the machine, use this chapter as a quick reference when you have to change a job setup.

The Manual Feeder M is used to feed stapled sets of up to three sheets by hand. See page 30 for an explanation of how to set up and use this feeder.

Job Listing

ALL MODELS

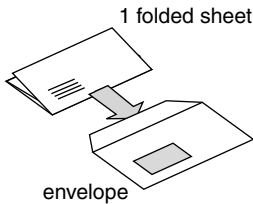

JOB 1 Page 17

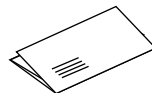

JOB 2 Page 18

MODELS with an INSERT FEEDER C

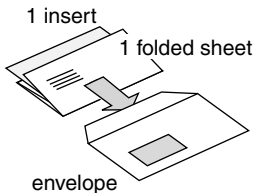

JOB 3 Page 19

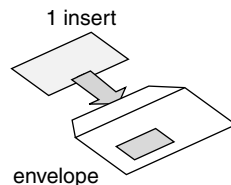

JOB 4 Page 21

Running

MODELS with an OPTIONAL SECOND SHEET FEEDER A2

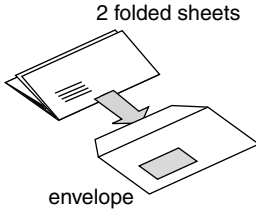

JOB 5 Page 22

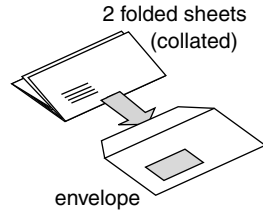

JOB 6 Page 23
* see note below



2 folded sheets
no envelope (fold only)

JOB 7 Page 24



2 folded sheets
(collated)
no envelope (fold only)

JOB 8 Page 25
* see note below

MODELS with an INSERT FEEDER C and SECOND SHEET FEEDER A2

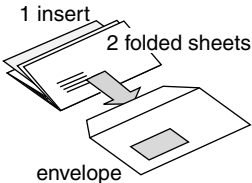

JOB 9 Page 26

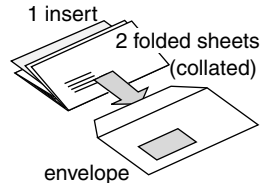

JOB 10 Page 28
* see note below

NOTE: Jobs marked with an asterisk (*) use the second sheet feeder, A2, in “2nd Page” mode to feed 2-sheet collated sets. You must load sheets into the feeder in their collated sequence: first page, second page, first page, second page, etc., just as they are printed by a typical office laser printer.

One Folded Sheet into an Envelope

Model Required: Any OfficeRight™DI200

Notes: If your machine has the optional 2nd sheet feeder A2, you can use it instead of A1, as long as you load and select it as described in steps 1 and 3 below.

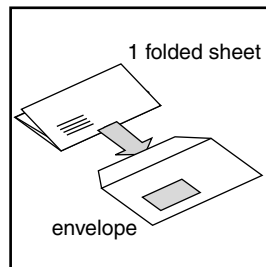

Step	Action	Tip	More Details...
1	Make sure paper size setting is correct	Choose 11" or 14"	Page 32
2	Load sheets into Sheet Feeder A1	Load face down and bottom edge first	Page 12
3	Load envelopes into Feeder B	Load right way up and facing you	Page 13
4	Press button to select Feeder A1	Make sure green indicator lights	Page 8, 9
5	Press button to select Envelope Fdr B	Make sure green indicator lights	Page 8, 9
6	Press button to choose Seal or No Seal	Make sure moistener has E-Z Seal® or water	Page 8, 9
7	Press Trial Piece button and check trial piece	Trial piece will not seal—this is normal	Page 8, 9
8	Press Start button to run job	Stop button will stop machine at end of cycle	Page 8, 9

Problems? See *Error Messages*, page 35, and *Troubleshooting*, page 39

Job 2

One Folded Sheet, No Envelope (Fold Only)

Model Required: Any OfficeRight™DI200

Notes: If your machine has the optional 2nd sheet feeder A2, you can use it instead of Feeder A1, as long as you load and select it as described in steps 1 and 3 below.

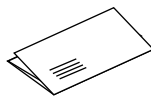

1 folded sheet
no envelope (fold only)

Step	Action	Tips	More Details...
1	Make sure paper size setting is correct	Choose 11" or 14"	Page 32
2	Load sheets into Sheet Feeder A1	Load face down and bottom edge first	Page 12
3	Press button to select Feeder A1	Make sure green indicator lights	Page 8, 9
4	Press button to select Fold Only	Make sure green indicator lights	Page 8, 9
5	Press Trial Piece button	Check trial piece and look for a good fold	Page 8, 9
6	Press Start button to run job	Stop button will stop machine at end of cycle	Page 8, 9

Problems? See *Error Messages*, page 35, and *Troubleshooting*, page 39

One Folded Sheet + One Insert into an Envelope

Model Required: OfficeRight™DI200 *must* have an Insert Feeder C

Notes: Inserts are pre-folded sheets or unfolded items such as business reply envelopes, response cards and similar items. If your machine has the optional 2nd sheet feeder A2, you can use it instead of Feeder A1, as long as you load and select it as described in steps 1 and 4 below.

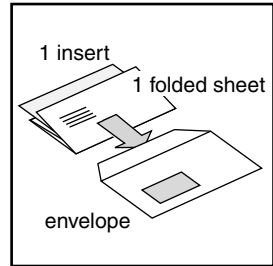

Step	Action	Tips	More Details...
1	Make sure paper size setting is correct	Choose 11" or 14"	Page 32
2	Load sheets into Sheet Feeder A1	Load face down and bottom edge first	Page 12
3	Load envelopes into Feeder B	Load right way up and facing you	Page 13
4	Load inserts into Insert Feeder C	Loading orientation depends on item	Page 14
5	Press button to select Feeder A1	Make sure green indicator lights	Page 8, 9
6	Press button to select Envelope Fdr B and Insert Fdr C	Make sure BOTH green indicators are lit	Page 8, 9
7	Press button to choose Seal or No Seal	Make sure moistener has E-Z Seal® or water	Page 8, 9

Continues on next page...

One Folded Sheet + One Insert into an Envelope (continued)

Step	Action	Tips	More Details...
8	Press Trial Piece button and check trial piece	Trial piece will not seal—this is normal	Page 8, 9
9	Press Start button to run job	Stop button will stop machine at end of cycle	Page 8, 9

Problems? See *Error Messages*, page 35, and *Troubleshooting*, page 39

One Insert into an Envelope

Model Required: Your OfficeRight™ DI200 *must* have an Insert Feeder C.

Notes: Inserts are pre-folded sheets or unfolded items such as business reply envelopes, response cards and similar materials.

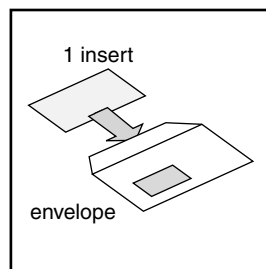

Step	Action	Tips	For More Details...
1	Load envelopes into Feeder B	Load right way up and facing you	Page 13
2	Load inserts into Insert Feeder C	Loading orientation depends on item	Page 14
3	Press button to select Envelope Fdr B and Insert Fdr C	Make sure BOTH green indicators are lit	Page 8, 9
4	Press A1/A2 select button until both feeders and 2nd Page are turned OFF	Make sure NO indicators are lit for A1 or A2 or 2nd Page	Page 8, 9
5	Press button to choose Seal or No Seal	Make sure moistener has E-Z Seal® or water	Page 8, 9
6	Press Trial Piece button and inspect trial piece	Trial piece will not seal—this is normal	Page 8, 9
7	Press Start button to run job	Stop button will stop machine at end of cycle	Page 8, 9

Problems? See *Error Messages*, page 35, and *Troubleshooting*, page 39

Job 5

Two Folded Sheets into an Envelope

Model Required: Your OfficeRight™ DI200 *must* have the optional Sheet Feeder A2.

Notes: Run the address-bearing document from Sheet Feeder A2 and a second sheet that needs folding from Sheet Feeder A1.

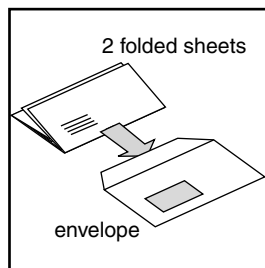

Step	Action	Tips	For More Details...
1	Make sure paper size setting is correct	Choose 11" or 14"	Page 32
2	Load addressed sheets into Sheet Feeder A2	Load face down and bottom edge first	Page 12
3	Load second sheets into Sheet Feeder A1	Load face down and bottom edge first	Page 12
4	Load envelopes into Feeder B	Load right way up and facing you	Page 13
5	Press button to select Feeders A1 and A2 .	Make sure BOTH green indicators are lit	Page 8, 9
6	Press button to select Envelope Fdr B	Make sure green indicator lights	Page 8, 9
7	Press button to choose Seal or No Seal	Make sure moistener has E-Z Seal® or water	Page 8, 9
8	Press Trial Piece button and check trial piece	Trial piece will not seal—this is normal	Page 8, 9
9	Press Start button to run job	Stop button will stop machine at end of cycle	Page 8, 9

Problems? See *Error Messages*, page 35, and *Troubleshooting*, page 39

Two Collated, Folded Sheets into an Envelope

Model Required: Your OfficeRight™ DI200 *must* have the optional Sheet Feeder A2.

Notes: This job uses the second sheet feeder A2 in 2nd Page mode to feed two-sheet, collated sets. Load sheets into the feeder in their collated sequence: page one, page two, page one, page two and so on.

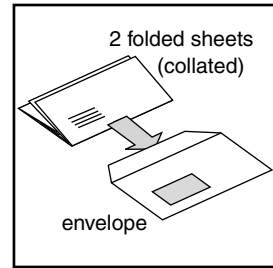

Step	Action	Tips	For More Details...
1	Make sure paper size setting is correct	Choose 11" or 14"	Page 32
2	Load sheets into Sheet Feeder A2. See note above for loading sequence	Load face down and bottom edge first	Page 12
3	Load envelopes into Feeder B	Load right way up and facing you	Page 13
4	Press button to select Feeder A2 and 2nd Page	Make sure BOTH green indicators are lit	Page 8, 9
5	Press button to select Envelope Fdr B	Make sure green indicator lights	Page 8, 9
6	Press button to choose Seal or No Seal	Make sure moistener has E-Z Seal® or water	Page 8, 9
7	Press Trial Piece button and check trial piece	Trial piece will not seal—this is normal	Page 8, 9
8	Press Start button to run job	Stop button will stop machine at end of cycle	Page 8, 9

Problems? See *Error Messages*, page 35, and *Troubleshooting*, page 39

Job 7

Two Folded Sheets, No Envelope (Fold Only)

Model Required: Your OfficeRight™ DI200 *must* have an optional Sheet Feeder A2.

Notes: Run the address-bearing document from Sheet Feeder A2 and a second sheet that needs folding from Sheet Feeder A1.

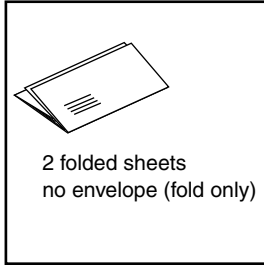

Step	Action	Tips	For More Details...
1	Make sure paper size setting is correct	Choose 11" or 14"	Page 32
2	Load addressed sheets into Sheet Feeder A2	Load face down and bottom edge first	Page 12
3	Load second sheets into Sheet Feeder A1	Load face down and bottom edge first	Page 12
4	Press button to select Feeder A1 and Feeder A2	Make sure BOTH green indicators are lit	Page 8, 9
5	Press button to select Fold Only	Make sure green indicator lights	Page 8, 9
6	Press Trial Piece button and check trial piece	Check trial piece for a good fold	Page 8, 9
7	Press Start button to run job	Stop button will stop machine at end of cycle	Page 8, 9

Problems? See *Error Messages*, page 35, and *Troubleshooting*, page 39

Two Collated, Folded Sheets, No Envelope (Fold Only)

Model Required: Your OfficeRight™ DI200 *must* have an optional Sheet Feeder A2.

Notes: This job uses the second sheet feeder A2 in 2nd Page mode to feed two-sheet collated sets. Load sheets into the feeder in collated sequence: first page, second page, first page, second page and so on.



2 folded sheets
(collated)
no envelope (fold only)

Step	Action	Tips	For More Details...
1	Make sure that paper size setting is correct	Choose 11" or 14"	Page 32
2	Load sheets into Sheet Feeder A2. See note above for loading sequence	Load face down and bottom edge first	Page 12
3	Press button to select Feeder A2 and 2nd Page	Make sure BOTH green indicators are lit	Page 8, 9
4	Press button to select Fold Only	Make sure green indicator lights	Page 8, 9
5	Press Trial Piece button and check trial piece	Check trial piece for a good fold	Page 8, 9
6	Press Start button to run job	Stop button will stop machine at end of cycle	Page 8, 9

Problems? See *Error Messages*, page 35, and *Troubleshooting*, page 39

Job 9

Two Folded Sheets and an Insert into an Envelope

Model Required: Your OfficeRight™ DI200 *must* have the optional Sheet Feeder A2 and an Insert Feeder C

Notes: Run the address-bearing document from Sheet Feeder A2 and a second sheet that needs folding from Sheet Feeder A1. Inserts are pre-folded sheets or unfolded items such as business reply envelopes, response cards and similar materials.

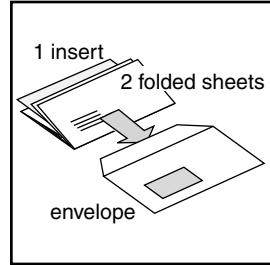

Step	Action	Tips	For More Details...
1	Make sure that paper size setting is correct	Choose 11" or 14"	Page 32
2	Load addressed sheets into Sheet Feeder A2	Load face down and bottom edge first	Page 12
3	Load second sheets into Sheet Feeder A1	Load face down and bottom edge first	Page 12
4	Load envelopes into Feeder B	Load right way up and facing you	Page 13
5	Load inserts into Insert Feeder C	Loading orientation depends on item	Page 14
6	Press button to select Feeder A1 and Feeder A2	Make sure BOTH green indicators are lit	Page 8, 9
7	Press button to select Envelope Fdr B and Insert Fdr C	Make sure BOTH green indicators are lit	Page 8, 9
8	Press button to choose Seal or No Seal	Make sure moistener has E-Z Seal® or water	Page 8, 9

Two Folded Sheets and an Insert into an Envelope (continued)

Step	Action	Tips	For More Details...
9	Press Trial Piece button and check trial piece	Trial piece will not seal—this is normal	Page 8, 9
10	Press Start button to run job	Stop button will stop machine at end of cycle	Page 8, 9

Problems? See *Error Messages*, page 35, and *Troubleshooting*, page 39

Job 10

Two Collated, Folded Sheets and an Insert into an Envelope

Model Required: Your OfficeRight™ DI200 *must* have the optional Sheet Feeder A2 and an Insert Feeder C.

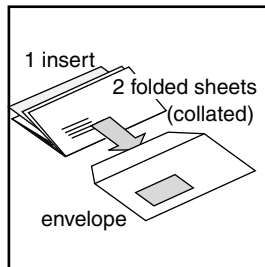

Notes: This job uses the second sheet feeder A2 in 2nd Page mode to feed two-sheet, collated sets. Load sheets into the feeder in collated sequence: first page, second page, first page, second page and so on. Inserts are pre-folded sheets or unfolded items such as business reply envelopes, response cards and so on.

Step	Action	Tips	For More Details...
1	Make sure that paper size setting is correct	Choose 11" or 14"	Page 32
2	Load sheets into Sheet Feeder A2. See note above for loading sequence	Load face down and bottom edge first	Page 12
3	Load envelopes into Feeder B	Load right way up and facing you	Page 13
4	Load inserts into Insert Feeder C	Loading orientation depends on item	Page 14
5	Press button to select Feeder A2 and 2nd Page	Make sure BOTH green indicators are lit	Page 8, 9
6	Press button to select Envelope Fdr B and Insert Fdr C	Make sure BOTH green indicators are lit	Page 8, 9
7	Press button to choose Seal or No Seal	Make sure moistener has E-Z Seal® or water	Page 8, 9

Two Collated, Folded Sheets and an Insert into an Envelope (continued)

Step	Action	Tips	For More Details...
8	Press Trial Piece button and check trial piece	Trial piece will not seal—this is normal	Page 8, 9
9	Press Start button to run job	Stop button will stop machine at end of cycle	Page 8, 9

Problems? See *Error Messages*, page 35, and *Troubleshooting*, page 39

Manual Feed

The Manual Feeder M

All OfficeRight™ DI200 models have a Manual Feeder M that allows you to feed stapled sets of *up to three sheets*, one set at a time, for processing by the machine.

Using the manual feeder *automatically turns off both sheet feeders*. You can, however, use the manual feeder along with the envelope, insert, fold-only and sealer selections to run a variety of jobs manually.

To use the manual feeder, set up the machine as you normally would for the job you're running. The selections shown by the indicators for Sheet Feeders A1 and/or A2 will be *ignored* by the machine. All other selections apply to the manual job.

Feed stapled sets into the manual feeder in the normal orientation for sheets fed into the OfficeRight™ DI200; that is, *face down* and *bottom edge first*.

Take one stapled set and feed it gently into the manual feed slot until the machine automatically starts and draws the set from you. The machine processes the set and ejects it into the stacker in the usual manner.

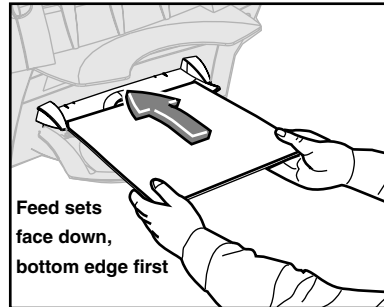

NOTES:

- Be sure to feed the set in squarely. If you feed it in at an angle, a poor fold or jam could result.
- Feed the set into the machine gently. Very little force is needed.
- The first set will *not* seal even if you set up the system to do so. This “trial” feature allows you to inspect the processed job to make sure that all pieces were inserted correctly and that the address appears in the envelope window.



CAUTION! Feeding more than three sheets in a set may damage your machine.

4. ADVANCED MENU OPTIONS

Press the *Menu/Enter* Button to get to the advanced menu options. These allow you to:

- **Reset the counter**

Choose this option if you want to set the piece counter back to zero.

- **Change paper size**

Choose this option to select letter-size sheets (8-1/2 x 11 inches) or legal-size sheets (8-1/2 x 14 inches).

- **Move the address in the window**

Select this menu option to center the address vertically in the envelope window

- **Turn sheet double detection on or off**

Turn this option on if you want the machine to stop automatically when it senses a double feed.

- **Turn insert double detection on or off**

Turn this option on if you want the machine to stop automatically when it detects a double insert feed.

- **Turn safe seal on or off**

Turn this option on if you need to improve envelope sealing quality.

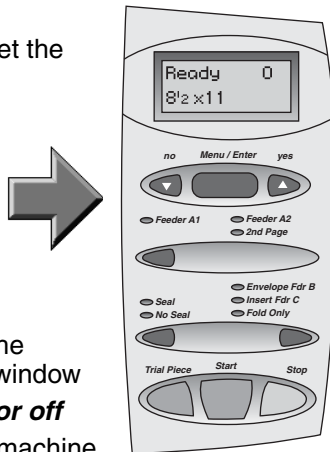

The above options appear in the order listed. To scroll through them, press the *Menu/Enter* button repeatedly until you see the option you want. Or press the *Menu/Enter* button once and answer *no* to each of the options as they appear. To return to the *Ready* screen at any time, press the *Menu/Enter* button repeatedly.

Reset Counter

This option allows you to reset the counter to zero. To access it, press the *Menu/Enter* button once. The screen Prompts: *Reset Counter?*

A rectangular box with a black border containing the text 'Reset Counter?' in a pixelated font.

Press *yes* (▲) to reset the counter and return to the ready screen. Press *no* (▼) to go to the next menu option.

The Menu

Change Paper Size

Choose this menu option to select the paper (sheet) size you want to run. You can set your OfficeRight™ DI200 to process letter-size sheets (8-1/2 x 11 inches) or legal-size sheets (8-1/2 x 14 inches).

```
Paper: 8-1/2 x 11  
Change Size?
```

```
Paper: 8-1/2 x 14  
Change Size?
```

Press the *Menu/Enter* button repeatedly until the display shows the current paper size selection: *Paper: 8-1/2 x 11 Change Size?* or *Paper: 8-1/2 x 14 Change Size?*

Press *yes* (▲) to change paper size. The display confirms the change. Press *no* (▼) to go to the next menu option without changing the paper size setting. Press the *Menu/Enter* button repeatedly to go back to the *Ready* screen.



IMPORTANT: Always make sure the sheets you load are the same size you've set the machine to run. If you load the wrong size sheets, the machine will jam.

Please note that the paper size setting applies to *all* your machine's sheet feeders: that is, Sheet Feeder A1; the optional Sheet Feeder A2 (if your machine is so equipped); and Manual Feeder M.



CAUTION: DO NOT intermix sheet sizes in the same job. The machine will jam if you attempt to do so.

Move the Address in the Window

This menu option allows you to change the length of the fold panel so that the address is centered in the envelope window. Make this adjustment if the address in your trial piece appears to be too high or too low in the window.

Make the adjustment by entering a number from 1 to 9. The *higher* the number, the *higher* the address will appear in the window.

Press the *Menu/Enter* button repeatedly until the screen displays:
Move address in window?

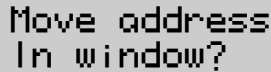

Move address
In window?

Press *yes* (▲) to enter the function. The screen displays: *Shift...X* (where X is the current setting)



Shift.. X
▼ Down ▲ Up

Set the desired number using the *yes* (▲) and *no* (▼) buttons. When you reach the setting you want, press the *Menu/Enter* button to confirm it. This takes you to the next menu option.

Run another trial piece and check it. If the address is centered in the window, press *Start* to run your job. If the address is not centered, repeat the procedure until you get the result you want.

Pressing *no* (▼) when you have the option to move the address in the window takes you to the next menu option.

Sheet Double Detect On/Off

This option lets you turn the sheet feeder(s) double document detection on or off.

When turned on...

The machine stops automatically when it senses a double feed (two sheets feed when only one should).

If you're running a job with individually addressed inserts, it's best to turn double detection on.



Sheet DD is
On. Change?

When turned off...

The machine ignores any double feeds that may occur. You may want to turn double detection off if you're running a mail job and it is of little concern if a mail recipient receives duplicate sheets.

Press the *Menu/Enter* button repeatedly until the display shows the sheet DD status: *Sheet DD is On (Off). Change?*

Press *yes* (▲) to change the sheet double detect status. The display will confirm the change. Press *no* (▼) to go to the next menu option without changing this setting.

The Menu

Insert Double Detect On/Off

This option lets you turn the insert feeder's double document detection on or off.

When turned on...

The machine records the thickness of the piece. When you start the run, the machine automatically stops when it senses a double feed.

When turned off...

The machine ignores any double feeds that may occur. You may want to leave double detection off if you are running a mail job and occasional duplicate inserts are not a concern.

Press the *Menu/Enter* button repeatedly until the display shows the insert DD status: *Insert DD is On (Off). Change?*



```
Insert DD is
On. Change?
```

Press *yes* (▲) to change the insert double detect setting. The display con-firms the change. Press *no* (▼) to go to the next option. The double detection setting remains unchanged.

Safe Seal On/Off

This option allows you to turn safe seal on or off. If you're having problems with envelope flaps not sticking, try turning this option on.

Safe seal slows the machine slightly, allowing more time for moisture to transfer onto the envelope flap during the seal cycle. Some gums require this added time to break down properly and become sticky. This function therefore produces a better seal on many types of envelopes.

Press the *Menu/Enter* button repeatedly until the display shows the safe seal status: *Safe Seal is On (Off). Change?*



```
Safe Seal is
On. Change?
```

Press *yes* (▲) to change the safe seal status. The display confirms the change. Press *no* (▼) to exit from the menu options without changing the safe seal setting.

5. REFERENCE

Error Messages

Message	Meaning and Action
CANNOT SHIFT ADDRESS ON INSERTS	No sheet feeder has been selected in the job setup. The display automatically times out from this message after two seconds and moves on to the turn double detect On/Off menu function.
CLOSE COVER D	The machine has detected that the front cover D is open. Check that cover D is closed properly.
CLOSE COVER E	The machine detected that the rear cover E is open. Check that cover E is closed properly.
CHECK AREAS A1 & D	Check for an unsuccessful clearance of a jam between the sheet feeder A1 and the collation area. Remove the paper in sheet feeder A1, open front cover D and check that the machine is clear of material. Close front cover D, reload and start run.
CHECK AREAS A1, A2 & D	This could be due to an unsuccessful clearance of a jam between the sheet feeders A1, A2 and the collation area. Remove the paper in sheet feeders A1, A2, open front cover D and check that the machine is clear of material. Close front cover D, reload and start run.
CHECK / CLEAR INSERT FDR C	Inserts failed to feed. Check that the side guides in feeder C are not too tight. Reload feeder C and start run.
CHECK SHEET FEEDER A1	Sheet feeder A1 out of paper, failed to feed or a jam was not cleared successfully from this area. Remove the paper in sheet feeder A1, reload and start run.

Reference

Message	Meaning and Action
CHECK SHEET FEEDER A2	Sheet feeder A2 out of paper, failed to feed, or a jam that was no cleared successfully from this area. Remove the paper in sheet feeder A2, reload and start run.
CHECK SHEET FEEDER A2 LIFT COVER D REMOVE ALL	The machine has detected a material jam between sheet feeder A2 and the collation area. Open the front cover D and remove all material inside. Close front cover D. Remove material from sheet feeder A2. Reload and start run.
CLEAR FEEDER M	This is due to the Manual Feeder M being blocked prior to powering the machine up or starting it up. Check that there's no material in the feeder. If there is, remove it and restart.
CLEAR STACKER AREA	This could be due either to a previous jam not being cleared correctly in the stacker area or there is a jam in the stacker area. Check that stacker area is clear. Remove any material and resume run.
DOUBLE FEED CHECK FDR A1	The machine has detected a double feed from sheet feeder A1. Remove the paper in sheet feeder A1, reload and start run.
DOUBLE FEED CHECK FDR A2	The machine has detected a double feed from sheet feeder A2. Remove the paper in sheet feeder A2, reload and start run.
FOLD ONLY REQUIRES SHEETS	Fold only has been selected but no sheets, either from feeder A1 or A2 (if applicable), have been selected. In this state the indicators for sheet feeder A1 will be red, not green. Press the sheet feeder selection button until the required feeder is selected.

Message	Meaning and Action
INSERT DOUBLE FEED	The machine has detected a double feed from the insert feeder. Lift cover D and remove material. Reload inserts and start run.
LIFT COVER D REMOVE ALL	This state could be produced by any kind of material crash in or near the insertion area, or a previous jam not being cleared correctly. It can also be caused by dust covering a sensor. Open front cover D and remove any material in the machine. Also blow out any dust that may have accumulated in the area. Close cover D and start run.
LIFT COVER D REMOVE ENV	This could be due to a previous envelope jam not being cleared correctly in the insertion area. Open front D, remove envelope and start run. If no envelope is visible in the machine, remove all material visible in the feeder then reload and start run.
OPEN COVER E REMOVE ALL	This could be due to a previous jam not being cleared correctly. Open rear cover E and remove any material in the machine. Close rear cover E and start run.
POWER ON/OFF	Turn off power to the machine, wait for a minute and then turn the power back on.
RELOAD ENVELOPES	Feeder B may be out of envelopes, or an envelope feed failed or was slow. Check that there are envelopes loaded. If not, reload and start run. If there are envelopes, check that the side guides on feeder B are not too tight and that you have not overloaded the envelopes. Reload feeder B and start run.
RELOAD INSERTS	Insert feeder C is empty. Reload inserts and start run.

Message

Meaning and Action

REMOVE ALL
FROM D & E

This could be due to a material jam in fold plate 1 or near the insertion area. Open front cover D and remove any material that's there. Close cover D. Open rear cover E and remove any material in the area. Close rear cover E and start run.

REMOVE ALL
FROM M & D

This is due to a poor feed from manual feeder M. Check that there's no material in manual feeder M. If there is, remove it. Also open front cover D and remove any material inside. Close front cover D, reload and start run.

REMOVE SHEET
FROM A1

A sheet has failed to feed from sheet feeder A1. Remove paper from A1, then reload and start run.

REPLACE
FDR A1 TRAY

Check that sheet feeder A1 is pushed fully into position.

SHEETS
REQUIRED

Envelopes have been selected but no sheet feeder was selected. The indicators for sheet feeder A1 and envelopes will be red. Press the sheet feeder selection button until the required feeder is selected.

SYSTEM ERROR
CALL SERVICE

This is an unrecoverable system error. Please call Pitney Bowes for assistance (see page 41).

General Troubleshooting

Poor folding

If you're running perforated material, the machine may have problems folding. If a machine fold almost corresponds with the perforation, a "box fold" may occur. This happens when another fold is created just off of the perforation and buckles slightly, creating, in effect, a third fold.

If this happens, adjust the machine fold slightly. Run a trial piece and inspect the fold. If there is a box fold, access the advanced menu options and select *move address in window*. Change the setting higher or lower and re-run a trial piece. Inspect the fold again and, if required, change the *move address in window* function until the box fold is eliminated.

Machine stops for doubles that aren't there

If you have a problem with incorrect double detection, it may be due to the fact that you are using a new batch of material that is slightly thicker. Try running a new trial piece.

When you ran the original trial piece, the machine calibrated itself to the original material thickness. When it senses the new, thicker material, the system thinks that a double was fed. You can turn double detection off if an occasional duplicate insert is not important (see pages 31 and 33).

Machine feeds doubles without stopping

Check that double detection is turned on. See page 33. Make sure you've run a trial piece. This automatically sets the double detector. See page 9.

Envelope flaps won't seal

- Check that **Seal** is selected (green indicator lit). See page 9.
- Check that the moistener isn't empty. See page 11.
- Try selecting safe seal mode. See page 34.

Address position wrong or address doesn't appear in envelope window

- Is the addressed sheet loaded properly? See page 12.
- Is the addressed sheet in Sheet feeder A2 (if installed)?
- Try adjusting the address position. See page 32.

Reference

Inserts or business reply envelopes feed poorly from Insert Feeder

Changing the orientation of the insert stack may help. For pre-folded inserts it's normally best to load with the closed edge feeding first. Business reply envelopes can normally be loaded right way up and facing you. However, if the flaps are pulled open when feeding, try loading with the flaps down and facing you.

Following installation of Sheet Feeder 2, the system doesn't work

- Check that the OfficeRight™ DI200 is correctly located onto Sheet Feeder 2.
- Turn the machine off, wait a few seconds and then turn it back on.
- Check that no debris (dust, paper, etc.) has fallen into the Sheet Feeder 2 electrical connector.

Clearing Material Jams

First, remove all paper from the affected feeders as indicated on the display. Then, if necessary, clear sheets

...from sheet feeders/manual feeder

If the display indicates a jam in the sheet feeder(s) or manual feeder areas, pull the feeder assembly from the machine as shown. Then carefully remove any stalled material from the machine.

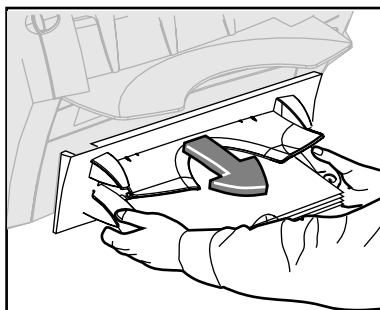

...from area beneath cover D

If the display indicates a jam beneath cover D, press the blue button marked **D** to release the cover. Lift the cover using the finger grips on each side of the stacker. Then carefully remove any stalled material from the machine.

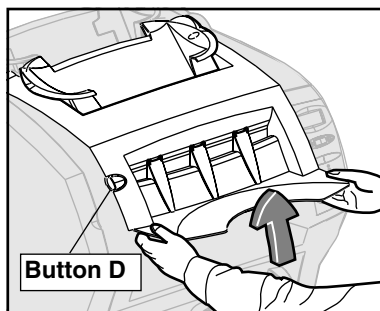

When closing the cover, latch it closed by pressing down on the finger grips or the central part of the cover in front of the envelope feeder. **DO NOT** press down on the stacker.

Continues on next page...

...from area beneath cover E

If the display indicates a jam beneath cover E, press the blue button marked **E** to release the cover. Push the cover backwards to gain full access.

Then carefully remove any stalled material from the machine.

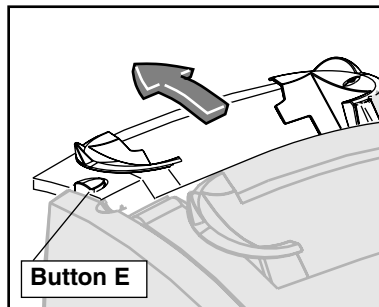

Getting Help

Should you experience a problem with your OfficeRight™ DI200, please refer to the troubleshooting information starting on page 39. In many cases, it should help you resolve the problem.

There may be times when you need additional help to solve a problem, or you may want more information about how to handle a particular Office-Right Mailer™ application.

Online Support

We encourage you to visit <http://www.pitneybowes.com/support>

The site offers helpful answers to frequently asked questions.

Phone Support

Technical help is readily available from our customer support line.

Before You Call...

Please have the following information at hand—

- Product name: **OfficeRight™ DI200**
- Serial number: This is located on the machine's back cover.
- Nature of the problem: What happens and when does it happen? Did the machine display an error message? What was it?
- The steps you've already taken to solve the problem and the results.

Then call:

In the USA 1.800.522.0020

In Canada 1.800.672.6937

Ordering Supplies

Pitney Bowes has made it easier than ever to order supplies—such as E-Z Seal® (Item Code 601-0, USA only) and Moistener Wick Replacement (Item Code 639-0)—that are designed specifically for your OfficeRight™ DI200.

Ordering Online (USA Only)

Just point your browser to <http://www.pitneybowes.com/supplies>

You'll find a complete, easy-to-navigate online store that offers a wide assortment of genuine Pitney Bowes supplies at attractive prices. Be sure to take advantage of special quantity pricing and online discounts.

Ordering by Phone

Our representatives will be happy to answer your questions and take your order.

☎ In the USA, call **1.800.243.7824**

☎ In Canada, call **1.800.672.6937**

Requesting a PB Supply Catalog (USA Only)

Call the number above or e-mail us at supplies@pb.com.

Material Specifications

Sheet Feeders A1 and/or A2:

Sheet Size	Letter (8-1/2 x 11") or Legal (8-1/2 x 14")
Paper Weight	20 to 24 lb. bond
Capacity	80 sheets of 20 lb. bond maximum
Limitations	DO NOT run NCR or litho/inkjet coated papers

Insert Feeder C (Optional):

Sheet Size	Width: 5 to 8-3/4" Depth: 3-3/8 to 3-7/8"
Material Weight	Unfolded document: 18 lb. bond to 80 lb. card stock Trifolded document: 18 to 24 lb. bond
Capacity	60 Business Reply Envelopes, 24 lb. bond, maximum
Type	Suitable for pre-folded, single panel inserts, business reply envelopes, etc.

Envelope Feeder B:

Envelope Size	Number 10 only Width: 9-1/2" Depth: 4-1/8"
Envelope Weight	18 to 24 lb. bond
Capacity	60 envelopes, 24 lb. bond, maximum
Envelope Flap Type	Executive (triangular) flap
Envelope Flap Length	1-1/4" to 2-1/4"
End Clearance	End clearance between the contents (inserts) and envelope must be a minimum of 1/4" on each side (1/2" overall). Take this measurement with <i>all</i> contents placed into the envelope.
Depth Clearance	The contents must allow a minimum clearance of 1/4" below the flap crease after insertion into the envelope.

Manual Feeder M

You can process stapled sets of up to three sheets of 20 lb. bond paper. Sheet Feeders A1 and A2 are not designed to work in conjunction with the Manual Feeder. We DO NOT recommend using glossy/coated sheets.

Sealer Capacity

The machine can seal up to a maximum of 1,000 envelopes between refills.

Stacker

Stacker capacity is up to 60 filled envelopes, depending on the contents of envelope.

Material Requirements

Materials should be of good quality and properly stored. Recommended storage conditions: 18 to 25°C; 40 to 60% relative humidity.

Machine Specifications

Physical Dimensions

Width	17-3/8"
Depth	20-3/4"
Height	14-3/8" (without optional sheet feeder 2) 17-3/8" (with optional sheet feeder 2)
Weight	38 lb. (17.5kg)

Electrical

115V, 60Hz, 1A

Speed

Up to a maximum of 900 cycles per hour

Due to our continuing program of product improvement, equipment and material specifications are subject to change without notice. Physical dimensions are approximate.

A

- Address
 - Not Centered in Window 39
 - Position Wrong 39
- Address-Bearing Sheet
 - Considerations when Using Sheet Feeder A2 7

C

- Cannot shift address on Inserts
 - Error Message 35
- Check Areas A1 & D
 - Error Message 35
- Check Areas A1, A2 & D
 - Error Message 35
- Check Sheet Feeder A1
 - Error Message 35
- Check Sheet Feeder A2
 - Error Message 36
- Check/Clear Insert Fdr C
 - Error Message 35
- Clear Feeder M
 - Error Message 36
- Clear Stacker Area
 - Error Message 36
- Close Cover D
 - Error Message 35
- Close Cover E
 - Error Message 35
- Configurations, Machine 5
- Control Panel
 - Location and Function of 6
- Controls, Front Panel
 - Illustration and explanation of 8
- Controls, Machine 6
- Counter
 - Resetting the Piece 31

D

- Display, Front Panel 8
- Double Detection
 - Insert
 - Turning On and Off 34
 - Sheet
 - Turning On and Off 32
- Double Feed Check Fdr A2
 - Error Message 36
- Doubles (Double Feed)
 - False Detection of 39
 - Machine Fails to Stop for 39

E

- E-Z Seal®
 - Importance of 11
- Envelope Feeder
 - Loading 13
- Envelope Feeder B
 - Location and Function of 7
- Equipment Specifications 43
- Error Message
 - Check Areas A1 & D 35
 - Close Cover D 35
 - Replace Fdr A1 Tray 38

Error Messages

- Cannot Shift Address on Inserts 35
- Check Areas A1, A2 & D 35
- Check Sheet Feeder A1 35
- Check Sheet Feeder A2 36
- Check/Clear Insert Fdr C 35
- Clear Feeder M 36
- Clear Stacker Area 36
- Double Feed Check Fdr A2 36
- Fold Only Requires Sheets 36
- Insert Double Feed 37
- Lift Cover D Remove All 37
- Lift Cover D Remove Env 37
- Open Cover E Remove All 37
- Power On/Off 37
- Reload Envelopes 37
- Reload Inserts 37
- Remove All from D & E 38
- Remove All from M & D 38
- Remove Sheet from A1 38
- Sheets Required 38
- System Error 38

F

- Feed, Manual 30
- Fold Only Requires Sheets
 - Error Message 36
- Folds Poor 39
- Front Cover D Release Button
 - Location and Function of 7

H

- Help, Getting 41

I

- Indicator Lights, Control Panel 9
- Insert Cover E Release Button
 - Location and Function of 6
- Insert Double Feed
 - Error Message 37

Insert Feeder

- Loading the 14
- Insert Feeder (Optional)
 - Location and Function of 6
- Inserts Feed Poorly 40

J

- Jam Clearance 40
- Jams
 - Clearing from Area Beneath Cover D 40
 - Clearing from Sheet Feeders 40
- Job Setup
 - One Folded Sheet + One Insert into an Envelope 19, 20
 - One Folded Sheet into an Envelope 17
 - One Folded Sheet, no Envelope (Fold Only) 18
 - One Insert into an Envelope 21
 - Two Collated, Folded Sheets and an Insert into an 27, 29
 - Two Collated, Folded Sheets into an Envelope 23
 - Two Collated, Folded Sheets, No Envelope (Fold Only) 25
 - Two Folded Sheets and an Insert into an Envelope 26
 - Two Folded Sheets and an Insert into an Envelope (c 27
 - Two Folded Sheets into an Envelope 22
 - Two Folded Sheets, No Envelope (Fold Only) 24
- Job Setups
 - Illustrated Guide to 15, 16
- Jobs, Running 15

L

- Lift Cover D Remove All
 - Error Message 37
- Lift Cover D Remove Env
 - Error Message 37
- Lifting Handles
 - Location and Function of 7
- Loading
 - Envelope Feeder 13
 - Insert Feeder 14
 - Sheet Feeders 12

M

- Machine Configurations 5
- Machine Controls, Indicators and Features 6
- Machine Specifications 44
- Manual Feed 30
- Manual Feeder M
 - Location and Function of 7
- Material Specifications 43
- Menu Options
 - Address, Centering in Window 32
 - Advanced 31
 - Double Detection
 - Turning On and Off 34
 - Double Detection , Sheet
 - Turning On and Off 32
 - Paper Size, Changing 32
 - Reset Counter 31
 - Safe Seal Feature
 - Turning On and Off 34
- Menu/Enter Button 8
- Moistener
 - Filling the 11
- Moistener Tank
 - Location and Function of 7

N

- No Button, Function of 8

O

- Open Cover E Remove All
 - Error Message 37
- Operating Guide Slot
 - Location of 6
- Ordering Supplies 42

P

- Paper Size, Changing 32
- Perforations
 - Problems Cause By 39
- Phone Support 41
- Power Connection 10
- Power On/Off
 - Error Message 37
- Problems. *See* Troubleshooting

R

- Reload Envelopes
 - Error Message 37
- Reload Inserts
 - Error Message 37
- Remove All from D & E
 - Error Message 38
- Remove All from M & D
 - Error Messages 38
- Remove Sheet from A1
 - Error Message 38
- Replace Fdr A1 Tray
 - Error Message 38
- Running Jobs 15

S

- Safe Seal Feature
 - Turning On and Off 34
- Safety Information 4
- Sealing
 - Poor
 - How to correct 34
- Sealing, Envelope
 - Poor 39
- Second Sheet Feeder A2
 - Location and Function of 7
- Selection Buttons, Control Panel 9
- Setting Up a Job. *See* Job Setups:
 - Illustrated Guide to
- Sheet Feeders A1 and A2
 - Loading 12
- Sheets Required
 - Error Message 38
- Sleep Mode, Explained 9
- Specifications
 - Machine 44
 - Material 43
- Standard Sheet Feeder A1
 - Location and Function of 7
- Start Button, Control Panel 9
- Stop Button, Control Panel 9
- Supplies, Ordering 42
- System Error
 - Error Message 38
- System Won't Work with Sheet Feeder 2 40

T

- Technical Support 41
- Trial Piece, Purpose of 9
- Troubleshooting 39
 - Address Position Wrong 39
 - Double Feeds Don't Stop Machine 39
 - Envelope Seals Bad 39
 - False Doubles 39
 - Folds Bad 39
 - Inserts Feed Poorly 40
 - System Won't Work 40
- Turning Machine On 10

W

- Web Address, Pitney Bowes 41

Y

- Yes Button, Function of 8

Operator Guide



Engineering the flow of communication™

1 Elmcroft Road
Stamford, Connecticut 06926-0700
www.pb.com

For Service or Supplies

PB Form SV40189-OG Rev. C 4/05

©2005 Pitney Bowes Inc.

All Rights Reserved

Printed in the USA



Printed on recyclable paper



* S V 4 0 1 8 9 - 0 G R E V C *